



ROBERT MAIER GmbH  
Werkzeug- und Maschinenbau

Präzision schafft Vertrauen...  
...wir schaffen Präzision



## DRIVEN TOOLS for CNC lathes with driven turret

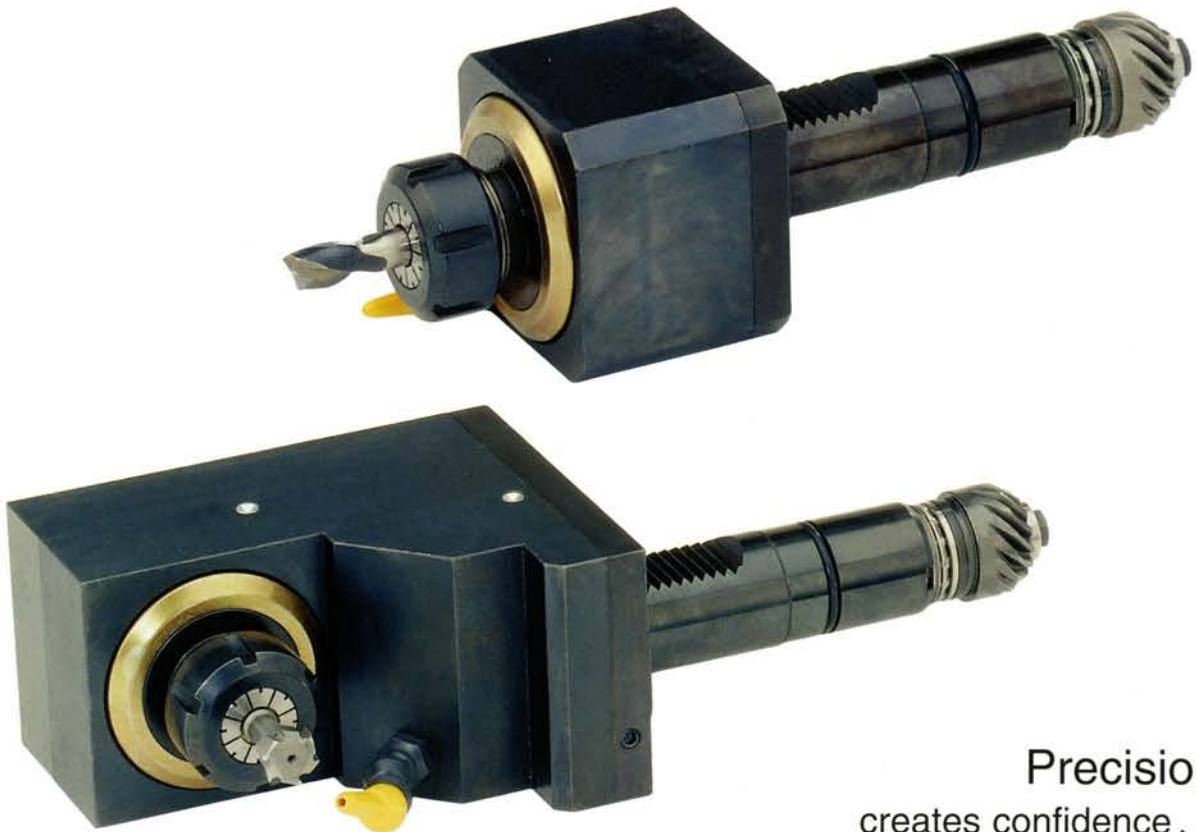

Precision  
creates confidence ...  
... we create  
Precision

### We produce for the future

We generate almost 50 % of our electricity requirements with our solar power station (photo-voltaic plant)





ROBERT MAIER GmbH  
Werkzeug- und Maschinenbau

Präzision schafft Vertrauen...  
...wir schaffen Präzision

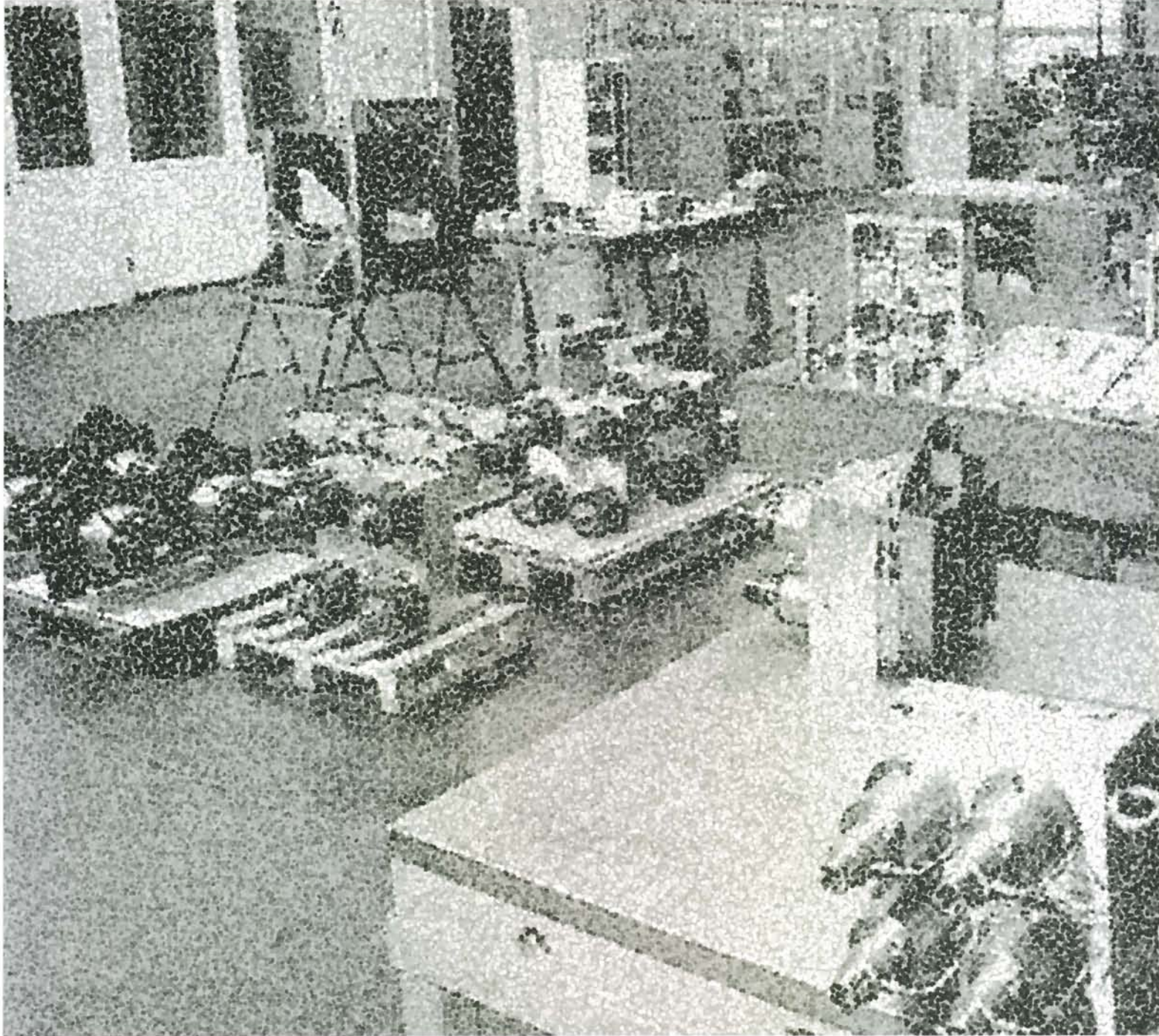



ROBERT MAIER GmbH  
Werkzeug- und Maschinenbau

Präzision schafft Vertrauen...  
...wir schaffen Präzision

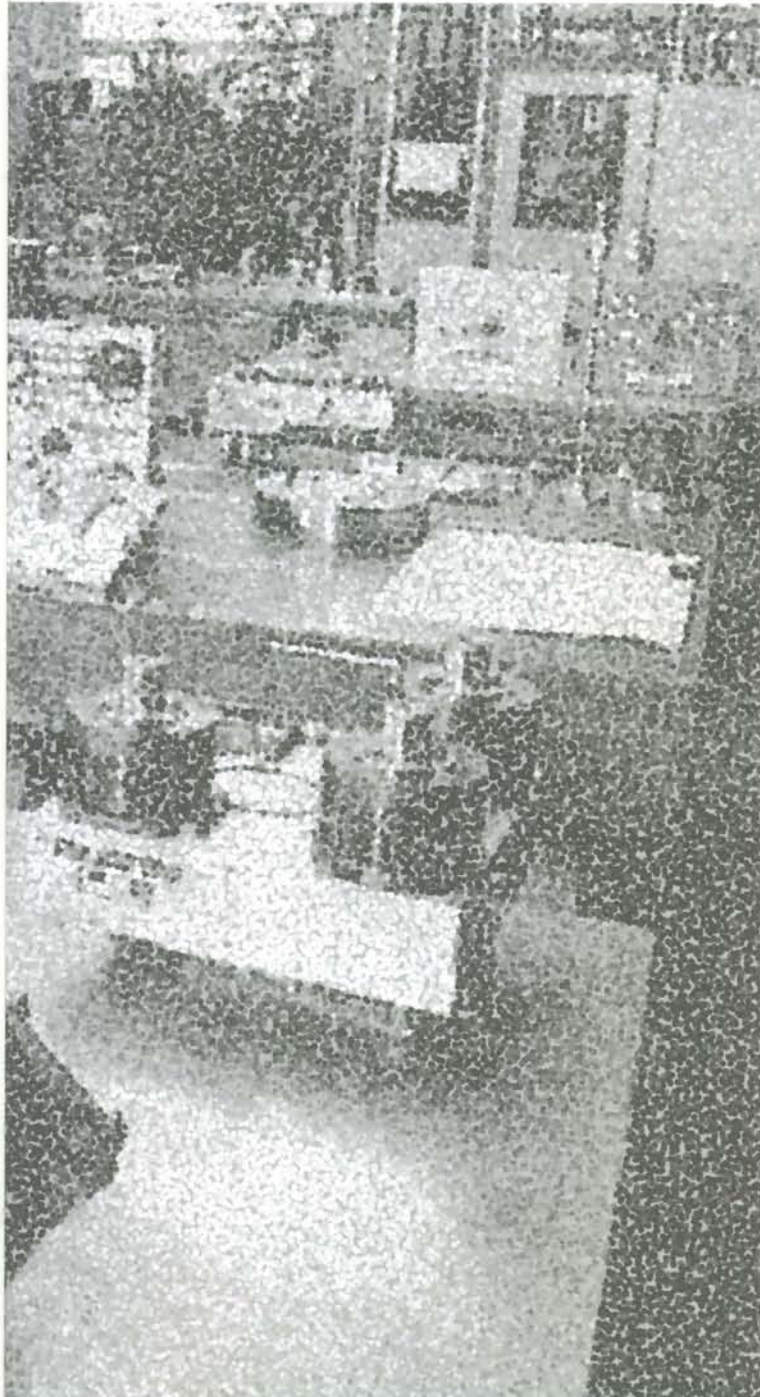

## PRECISION

– our governing principle through more than 45 years of company history.

An extensive programme of precision tools featuring highest **ROMAI** quality has consequently been developed since 1957.

With its comprehensive production line, the **ROMAI** company is in a position to respond to any specific wishes of its international customers in a fast, flexible and cost-oriented way.

At the company location with its state-of-the-art manufacturing facilities in Horrheim-Vaihingen/Enz right in the heart of Swabia, highly motivated employees develop, design and construct **ROMAI** precision products "Made in Germany".

Innovation, precision, quality and delivery on time are the standard for **ROMAI** customers all over the world.



Roland Maier  
President

## We produce for the future

We generate almost 50 % of our electricity requirements with our solar power station (photo-voltaic plant)



## Driven Tools

- Tools in radial and axial construction for all standard machine and turret types
- VDI shanks available in the sizes of 20 to 80, tool holding fixture according to desire
- Fast availability by modular design
- Extremely compact and space-optimized construction
- Economy-priced standard models available
- Special construction types available for specific machining problems, e.g. with multispindles or with inclined, swivelling or adjustable axes
- Available with internal and external coolant supply
- Single and multiple stage gear reductions and multiplications
- Universal execution with free-from-play pre-stressed tapered roller bearings for drilling, thread-cutting and light up to medium type milling work
- In precision execution with free-from-play pre-stressed spindle bearings, preferably for drilling works as well as fine and finish machining of any kind
- Special bearing for heavy-type milling work up to 500 Nm output torque



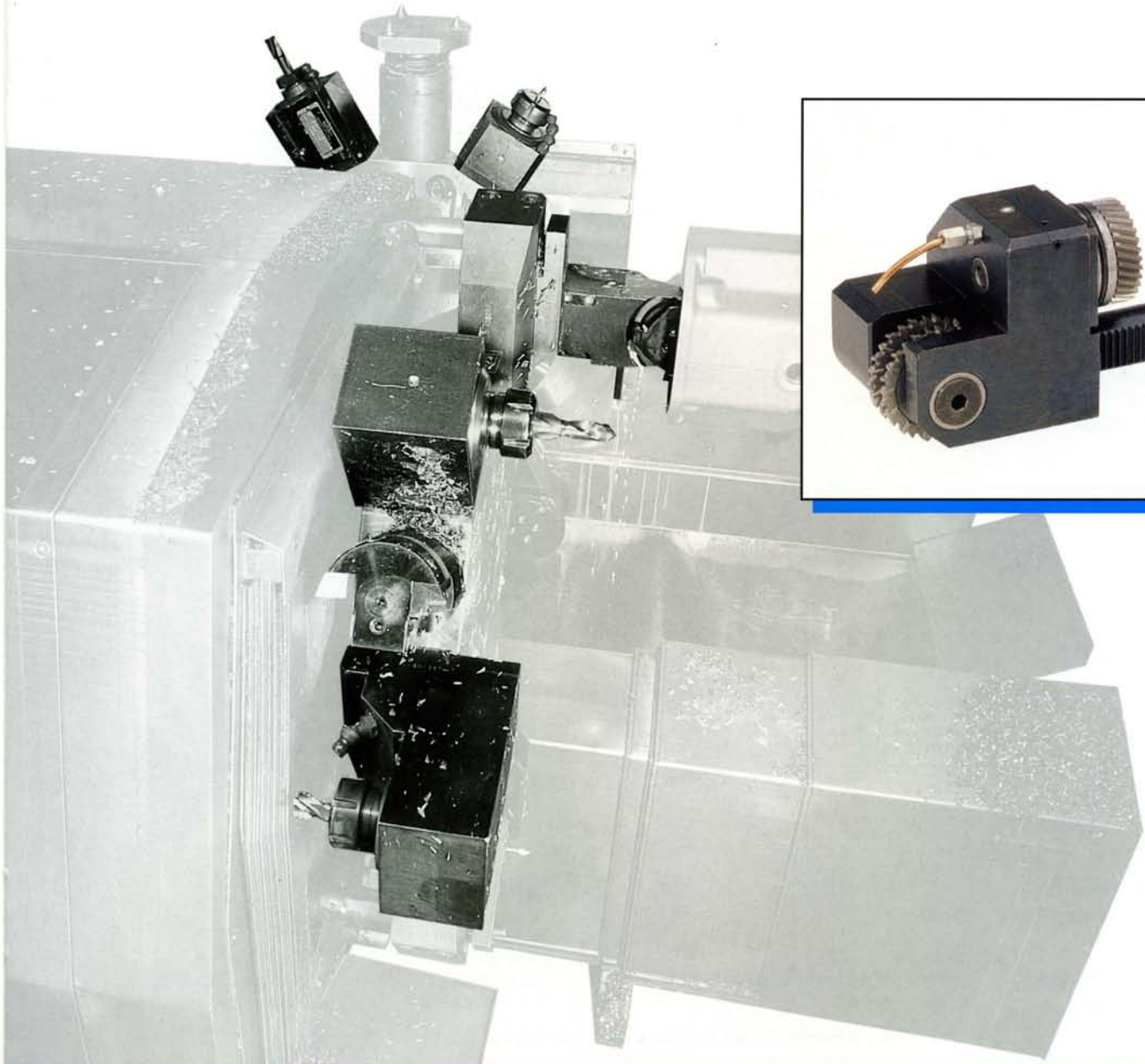

**We produce for the future**

We generate almost 50 % of our electricity requirements with our solar power station (photo-voltaic plant)



# AXIAL TOOL HOLDING FIXTURES

## AXIAL TOOL HOLDING FIXTURES with internal coolant supply

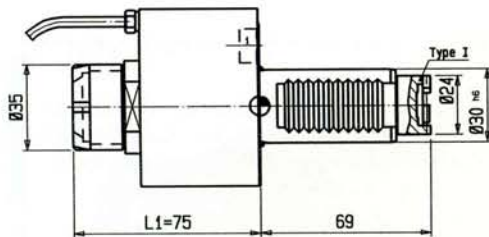

### Shank: VDI 30

collet chuck holding fixture: ER 25  
transmission: 1:1  
max. speed: 6000 rpm  
max. torque: 30 Nm (22 ft/lb)  
coolant pressure: 16 bar (240 PSI)

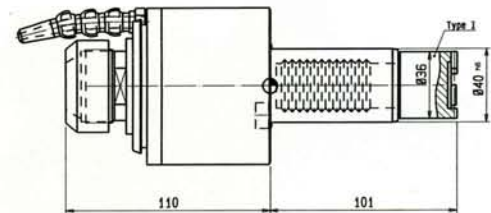

### Shank: VDI 40

collet chuck holding fixture: ER 32  
transmission: 1:1  
max. speed: 4500 rpm  
max. torque: 50 Nm (36 ft/lb)  
coolant pressure: 16 bar (240 PSI)

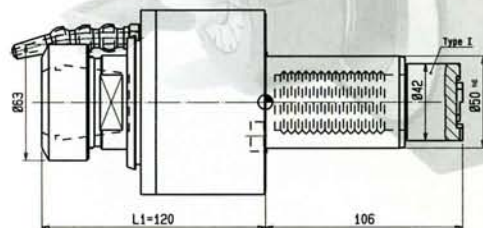

### Shank: VDI 50

collet chuck holding fixture: ER 40  
transmission: 1:1  
max. speed: 4000 rpm  
max. torque: 100 Nm (72 ft/lb)  
coolant pressure: 16 bar (240 PSI)

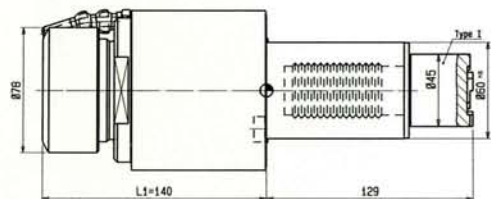

### Shank: VDI 60

collet chuck holding fixture: ER 50  
transmission: 1:1  
max. speed: 4000 rpm  
max. torque: 150 Nm (108 ft/lb)  
coolant pressure: 16 bar (240 PSI)

All standard tool holding fixtures available.





ROBERT MAIER GmbH  
Werkzeug- und Maschinenbau

Präzision schafft Vertrauen...  
...wir schaffen Präzision

# AXIAL TOOL HOLDING FIXTURES (transmission <math>\lt; 0</math>)

# AXIAL TOOL HOLDING FIXTURES (transmission <math>\lt; 0</math>) with internal coolant supply

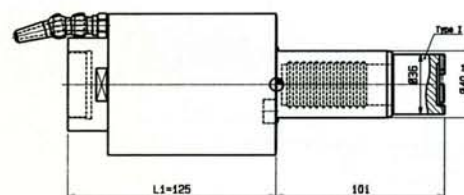
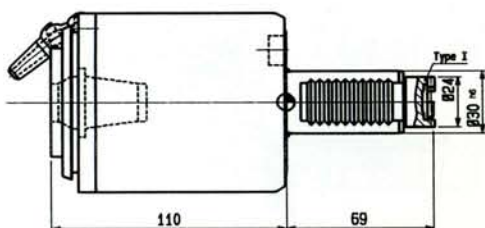

## Shank: VDI 30

collet chuck holding fixture: ER 25 A  
 transmission: 1:3 gearing-up  
 max. speed: 12000 rpm  
 max. torque: 10 Nm (7,5 ft/lb)  
 coolant pressure: 16 bar (240 PSI)

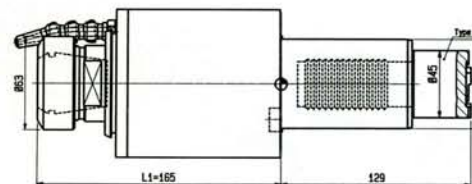
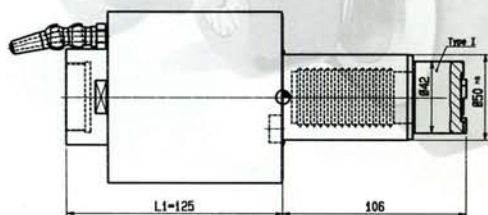
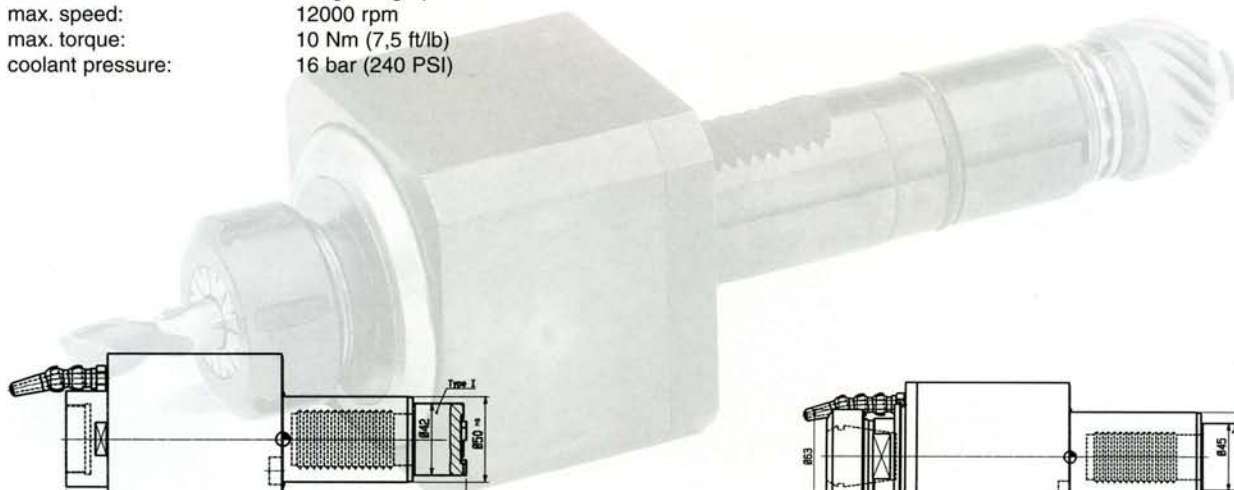

## Shank: VDI 50

collet chuck holding fixture: ER 32 A  
 transmission: 1:3 gearing-up  
 max. speed: 10000 rpm  
 max. torque: 25 Nm (18 ft/lb)  
 coolant pressure: 16 bar (240 PSI)

All standard tool holding fixtures available.

**We produce for the future**

We generate almost 50 % of our electricity requirements with our solar power station (photo-voltaic plant)





ROBERT MAIER GmbH  
Werkzeug- und Maschinenbau

Präzision schafft Vertrauen...  
...wir schaffen Präzision

# RADIAL TOOL HOLDING FIXTURES

## RADIAL TOOL HOLDING FIXTURES with internal coolant supply

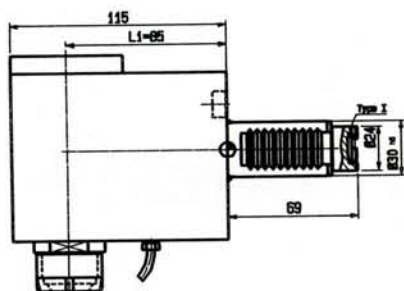

### Shank: VDI 30

collet chuck holding fixture: ER 25  
 transmission: 1:1  
 max. speed: 6000 rpm  
 max. torque: 30 Nm (22 ft/lb)  
 coolant pressure: 70 bar (1050 PSI)

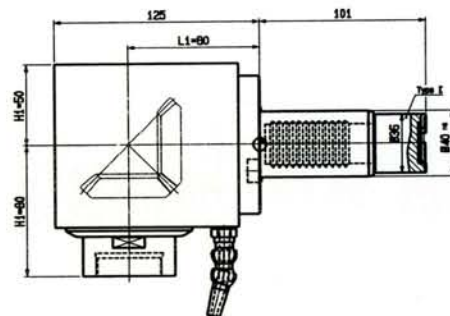

### Shank: VDI 40

collet chuck holding fixture: ER 32 A or ER 40 A  
 transmission: 1:1  
 max. speed: 4500 rpm  
 max. torque: 50 Nm (36 ft/lb)  
 coolant pressure: 70 bar (1050 PSI)

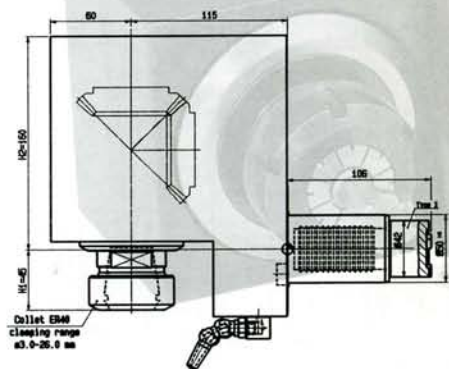

### Shank: VDI 50

collet chuck holding fixture: ER 40  
 transmission: 1:1  
 max. speed: 4000 rpm  
 max. torque: 100 Nm (72 ft/lb)  
 coolant pressure: 70 bar (1050 PSI)

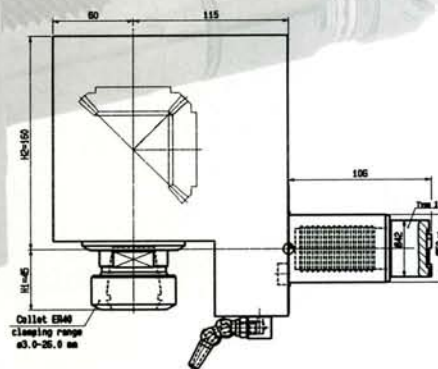

### Shank: VDI 60

collet chuck holding fixture: ER 50  
 transmission: 1:1  
 max. speed: 46000 rpm  
 max. torque: 100 Nm (72 ft/lb)  
 coolant pressure: 70 bar (1050 PSI)

All standard tool holding fixtures available.





# RADIAL TOOL HOLDING FIXTURES (transmission <math>\lt; 0</math>)

# RADIAL TOOL HOLDING FIXTURES (transmission <math>\lt; 0</math> with internal coolant supply)

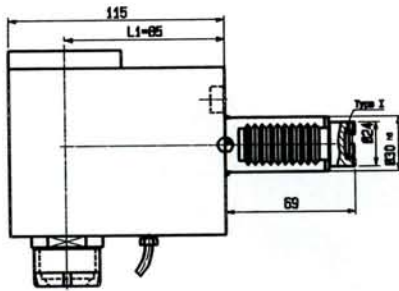

## Shank: VDI 30

collet chuck holding fixture: ER 25  
transmission: 1:2 gearing-up  
max. speed: 10000 rpm  
max. torque: 15 Nm (11 ft/lb)  
coolant pressure: 70 bar (1050 PSI)

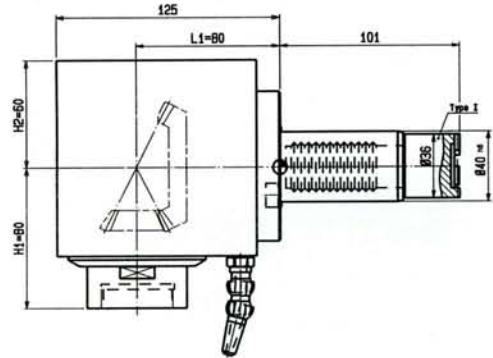

## Shank: VDI 40

collet chuck holding fixture: ER 32 A  
transmission: 1:2 gearing-up  
max. speed: 10000 rpm  
max. torque: 25 Nm (18 ft/lb)  
coolant pressure: 70 bar (1050 PSI)

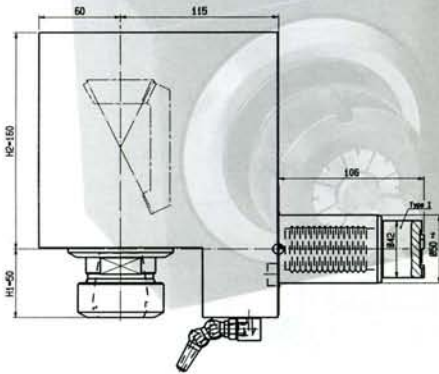

## Shank: VDI 50

collet chuck holding fixture: ER 40  
transmission: 1:2 gearing-up  
max. speed: 8000 rpm  
max. torque: 50 Nm (36 ft/lb)  
coolant pressure: 70 bar (1050 PSI)

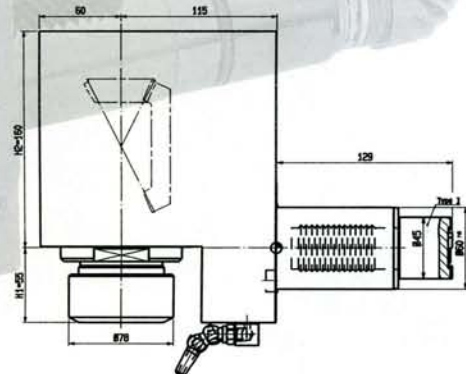

## Shank: VDI 60

collet chuck holding fixture: ER 50  
transmission: 1:2 gearing-up  
max. speed: 8000 rpm  
max. torque: 50 Nm (36 ft/lb)  
coolant pressure: 70 bar (1050 PSI)

All standard tool holding fixtures available.

**We produce for the future**

We generate almost 50 % of our electricity requirements with our solar power station (photo-voltaic plant)



# RADIAL TOOL HOLDING FIXTURES

set back

set back with internal coolant supply

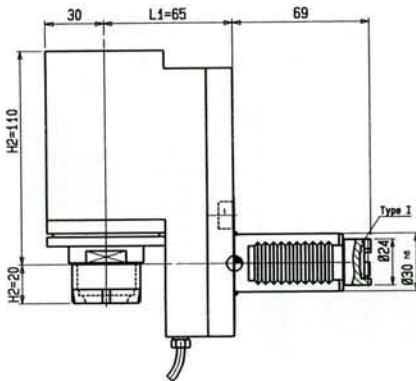

## Shank: VDI 30

collet chuck holding fixture: ER 25  
transmission: 1:1  
max. speed: 6000 rpm  
max. torque: 30 Nm (22 ft/lb)  
coolant pressure: 70 bar (1050 PSI)

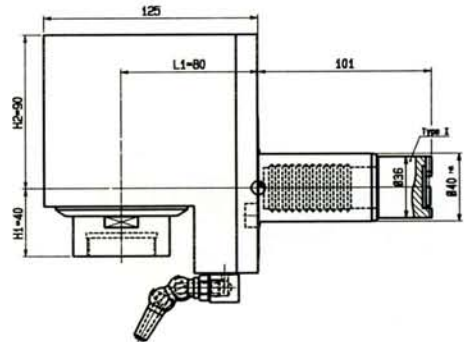

## Shank: VDI 40

collet chuck holding fixture: ER 32 A  
transmission: 1:1  
max. speed: 4500 rpm  
max. torque: 50 Nm (36 ft/lb)  
coolant pressure: 70 bar (1050 PSI)

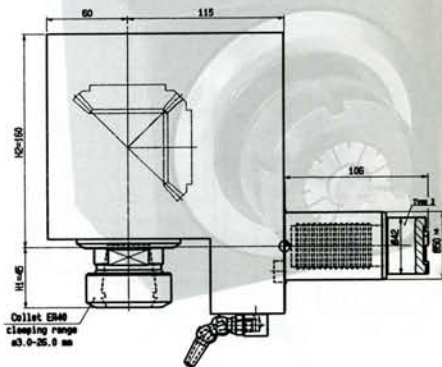

## Shank: VDI 50

collet chuck holding fixture: ER 40  
transmission: 1:1  
max. speed: 4000 rpm  
max. torque: 100 Nm (72 ft/lb)  
coolant pressure: 70 bar (1050 PSI)

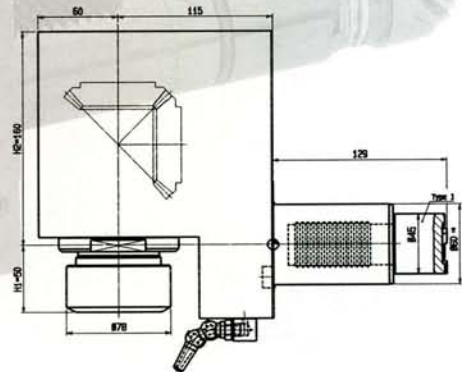

## Shank: VDI 60

collet chuck holding fixture: ER 50  
transmission: 1:1  
max. speed: 4000 rpm  
max. torque: 100 Nm (72 ft/lb)  
coolant pressure: 70 bar (1050 PSI)

All standard tool holding fixtures available.





ROBERT MAIER GmbH  
Werkzeug- und Maschinenbau

Präzision schafft Vertrauen...  
...wir schaffen Präzision

# RADIAL TOOL HOLDING FIXTURES set back (transmission $i < 0$ )

# RADIAL TOOL HOLDING FIXTURES set back with internal coolant supply

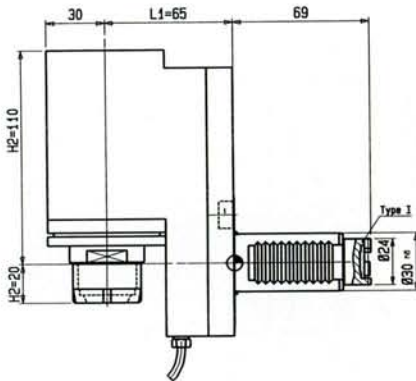

## Shank: VDI 30

collet chuck holding fixture: ER 25  
 transmission: 1:2 gearing-up  
 max. speed: 10000 rpm  
 max. torque: 15 Nm (11 ft/lb)  
 coolant pressure: 70 bar (1050 PSI)

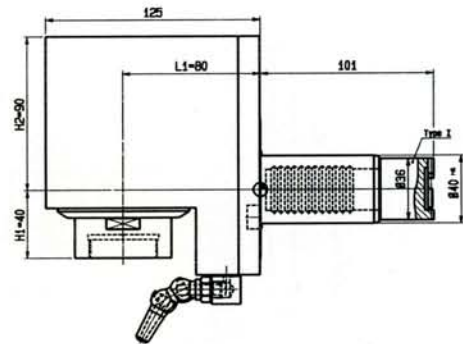

## Shank: VDI 40

collet chuck holding fixture: ER 32 A  
 transmission: 1:2 gearing-up  
 max. speed: 10000 rpm  
 max. torque: 25 Nm (18 ft/lb)  
 coolant pressure: 70 bar (1050 PSI)

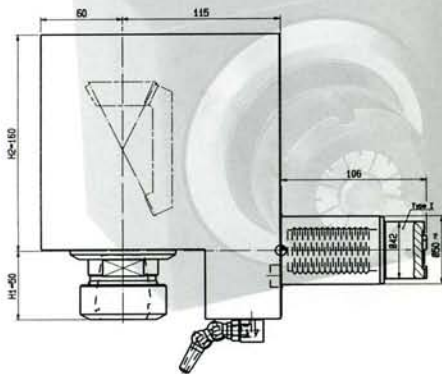

## Shank: VDI 50

collet chuck holding fixture: ER 40  
 transmission: 1:2 gearing-up  
 max. speed: 8000 rpm  
 max. torque: 50 Nm (36 ft/lb)  
 coolant pressure: 70 bar (1050 PSI)

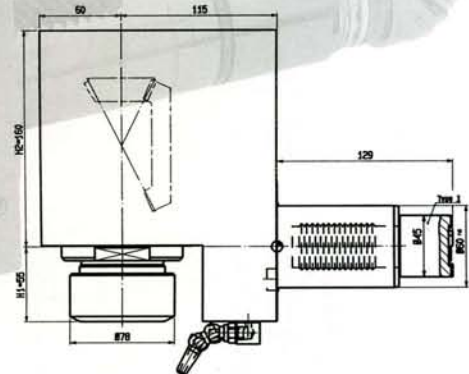

## Shank: VDI 60

collet chuck holding fixture: ER 50  
 transmission: 1:2 gearing-up  
 max. speed: 8000 rpm  
 max. torque: 50 Nm (36 ft/lb)  
 coolant pressure: 70 bar (1050 PSI)

All standard tool holding fixtures available.

We produce for the future

We generate almost 50 % of our electricity requirements with our solar power station (photo-voltaic plant)



## AXIAL Y-adjustable TOOL HOLDING FIXTURES

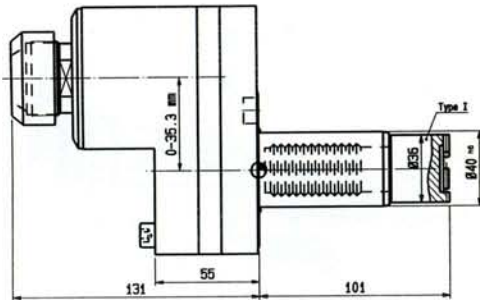

### Shank: VDI 40

collet chuck holding fixture: ER 32  
transmission: 2:1 gearing-down  
max. speed: 2250 rpm  
max. torque: 50 Nm (36 ft/lb)

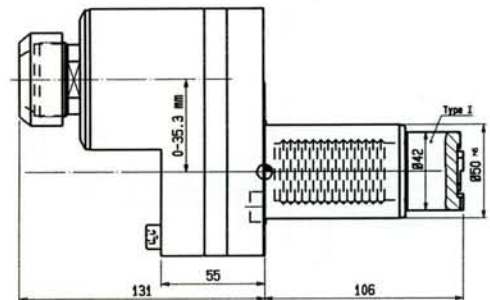

### Shank: VDI 50

collet chuck holding fixture: ER 32  
transmission: 2:1 gearing-down  
max. speed: 2250 rpm  
max. torque: 50 Nm (36 ft/lb)

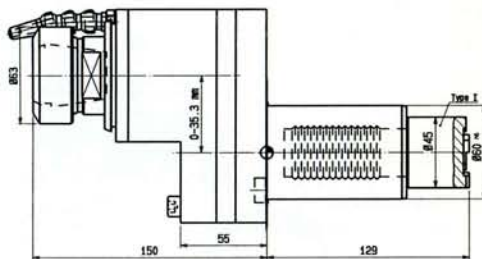

### Shank: VDI 60

collet chuck holding fixture: ER 40  
transmission: 2:1 gearing-down  
max. speed: 2250 rpm  
max. torque: 50 Nm (36 ft/lb)

All standard tool holding fixtures available.





ROBERT MAIER GmbH  
Werkzeug- und Maschinenbau

Präzision schafft Vertrauen...  
...wir schaffen Präzision

## ADJUSTABLE TOOL HOLDING FIXTURES

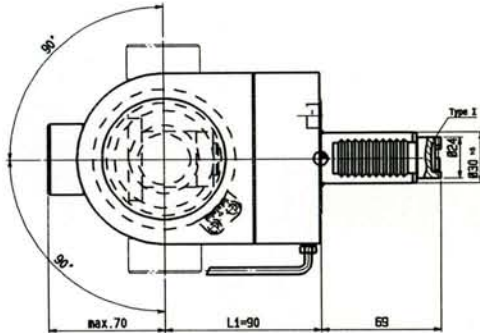

### Shank: VDI 30

collet chuck holding fixture: ER 25  
transmission: 1:1  
max. speed: 6000 rpm  
max. torque: 18 Nm (13 ft/lb)

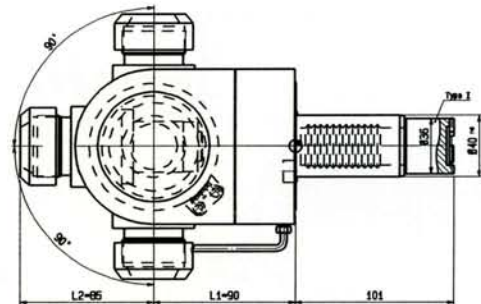

### Shank: VDI 40

collet chuck holding fixture: ER 32  
transmission: 1:1  
max. speed: 4500 rpm  
max. torque: 25 Nm (18 ft/lb)

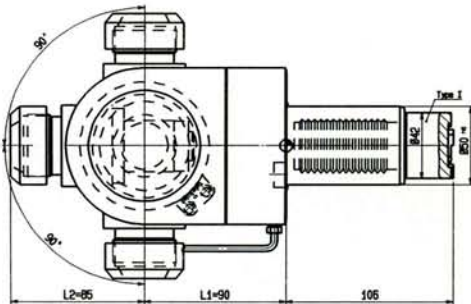

### Shank: VDI 50

collet chuck holding fixture: ER 32  
transmission: 1:1  
max. speed: 4500 rpm  
max. torque: 40 Nm (29 ft/lb)

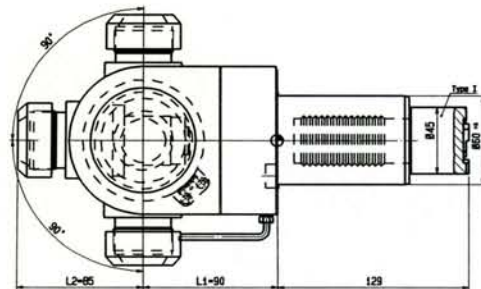

### Shank: VDI 60

collet chuck holding fixture: ER 40  
transmission: 1:1  
max. speed: 4500 rpm  
max. torque: 40 Nm (29 ft/lb)

All standard tool holding fixtures available.

**We produce for the future**

We generate almost 50 % of our electricity requirements with our solar power station (photo-voltaic plant)





ROBERT MAIER GmbH  
Werkzeug- und Maschinenbau

Präzision schafft Vertrauen...  
...wir schaffen Präzision

## RADIAL TOOL HOLDING FIXTURES with cutter arbor holding device

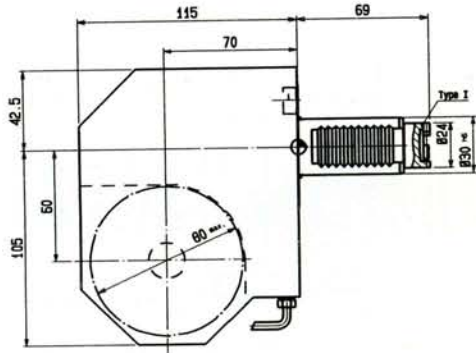

### Shank: VDI 30

cutter arbor holding device    Ø 20  
transmission:                    3:1 gearing-down  
max. speed:                      2000 rpm  
max. torque:                      50 Nm (36 ft/lb)

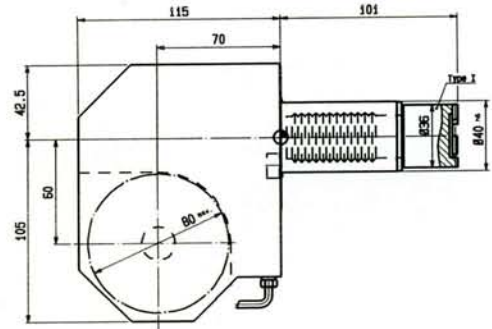

### Schaft: VDI 40

cutter arbor holding device    Ø 25  
transmission:                    3:1 gearing-down  
max. speed:                      2000 rpm  
max. torque:                      50 Nm (36 ft/lb)

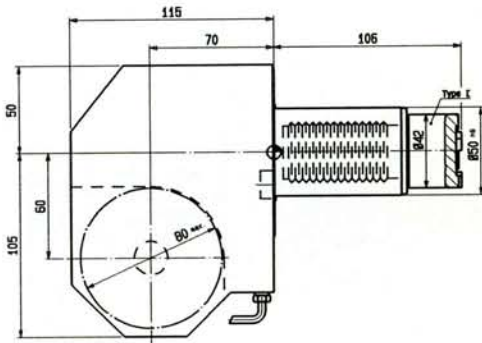

### Shank: VDI 50

cutter arbor holding device    Ø 25  
transmission:                    3:1 gearing-down  
max. speed:                      2000 rpm  
max. torque:                      100 Nm (73 ft/lb)

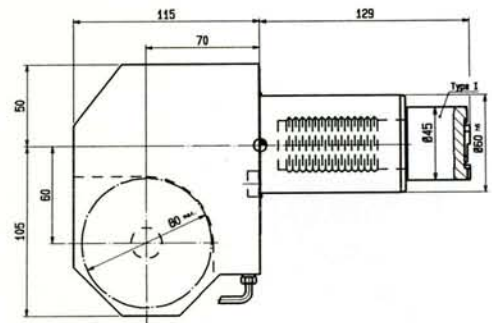

### Shank: VDI 60

cutter arbor holding device    Ø 25 or Ø 37  
transmission:                    3:1 gearing-down  
max. speed:                      2000 rpm  
max. torque:                      100 Nm (73 ft/lb)

Can be supplied with other cutter arbor holding devices and other transmissions, too.



## EXAMPLES for DRIVES and OUTPUTS

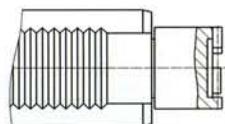

Spur coupling

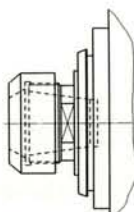

Collet chuck

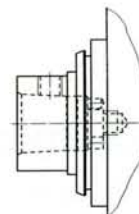

KM

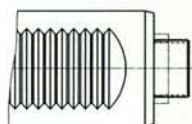

DIN 5481 / 5482

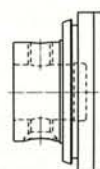

ABS

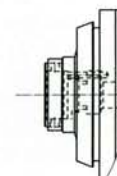

HSK

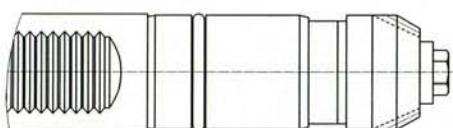

Bevel wheel

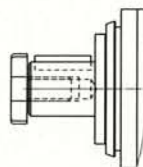

Cutting arbor

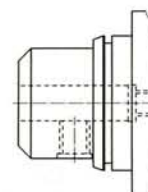

Weldon Whistle Notch

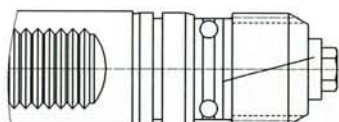

Spur wheel

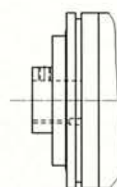

Threading chuck

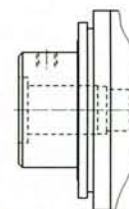

Expansion chuck

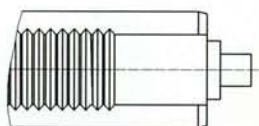

Carrier

**We produce for the future**

We generate almost 50 % of our electricity requirements with our solar power station (photo-voltaic plant)



Here is a short survey of our further delivery programme with various possibilities of application and use:

## ANGULAR BORING AND MILLING HEADS

- With torque support, 3- or 4-point support or fixed adaptation, suitable for all standard machine tools and machining centers
- Changes are performed automatically or manually
- Reduces the number of work mountings
- For drilling, frictioning, countersinking, thread-cutting and milling
- Enables the machining of work areas that are otherwise inaccessible (e.g. inside machining)
- Numerous special designs (e.g. hydraulically rotatable) for complicated machining problems
- Twin or multispindle variants are available, too
- Angle of axis adjustable, equal or unequal 90°
- Helical gear units with Gleason or Klingelnberg gear tooth forms
- On request available with internal coolant supply through the spindle
- For precision machining or rough working up to 1,000 Nm output torque



## Rigid Multispindle Heads

- For tool machines of any kind with quick-release taper, hollow taper shank (HSK) or other interfaces
- For machining centers with automatic tool change
- For flexible production systems with boring head change appliance
- Ideal for producing medium and large quantity series
- Many possibilities of application and fields of use
- Can be realized from 2 to 252 spindles
- Long tool-lives, low maintenance construction
- Spindle design and construction individually adapted to the task of machining





## Articulated Multispindle Heads

- Problem-free attachment to almost any driving engine
- Suitable for small series production
- High rationalization potential
- Simple adaptation of the drilling patterns to your specific tasks of machining
- Modular system makes favourable price and short delivery times possible
- Available in 54 standard sizes and many special executions
- Accessories and spare parts from stock
- Constructed from cast part, distributor gear, cardan shafts, spindle reception plate and precision drilling / threaded spindles
- On request available with springborn tool guide
- Service-friendly design and configuration
- Included in our delivery programme for over 40 years



## High-Speed Spindles

- For the use of modern cutting materials with high cutting speeds on slowly rotating or older types of tool machines
- Specially suitable for finish or fine machining
- Planetary gear with gearing-up to 1:6
- Planet wheels are flank-ground for smooth running
- Spindles equipped with free-from-play pre-stressed precision angular ball bearings
- Free of maintenance through lifetime lubrication
- On request with coolant supply through the spindle



## We produce for the future

We generate almost 50 % of our electricity requirements with our solar power station (photo-voltaic plant)





ROBERT MAIER GmbH  
Werkzeug- und Maschinenbau

Präzision schafft Vertrauen...  
...wir schaffen Präzision

Please send your inquiry to  
fax No.: +49 (0) 7042 / 83 21-22  
or contact us via <http://www.romai.de>

**Please provide me with:**

detailed brochures concerning:

- Axial tool holding fixtures
- Radial tool holding fixtures
- Axial Y-adjustable tool holding fixtures
- Angle-adjustable tool holding fixtures
- Radial tool holding fixtures with cutting arbor holding device

literature on our further delivery programme

.....  
.....

Please contact me by phone

**My data:**

.....  
company

.....  
full name

.....  
street

.....  
post code / town / country

.....  
telephone

.....  
telefax

.....  
e-mail

.....  
date

.....  
company stamp / signature





ROBERT MAIER GmbH  
Werkzeug- und Maschinenbau

Präzision schafft Vertrauen...  
...wir schaffen Präzision

- Notes
- Drafts
- Ideas

### **We produce for the future**

We generate almost 50 % of our electricity requirements with our solar power station (photo-voltaic plant)





ROBERT MAIER GmbH  
Werkzeug- und Maschinenbau

Präzision schafft Vertrauen...  
...wir schaffen Präzision



**ROBERT MAIER GmbH**  
Tool Manufacture and Machine Building

P. O. Box 60, D-71660 Vaihingen/Enz-Horrheim (Germany)  
Florianstrasse 22, D-71665 Vaihingen/Enz-Horrheim (Germany)  
Telephone +49 (0)70 42 / 83 21- 0  
Telefax +49 (0)70 42 / 83 21- 22  
e-mail: [info@romai.de](mailto:info@romai.de) – <http://www.romai.de>

